

ÖZKAN Needle Valve

Technical Guide W4.34

For continuous flow, pressure and isolation control.



10.21 | W4.34 ÖZKAN NEEDLE VALVE

Applications

Reservoir inlets
 Flow control
 Pipe burst safety valve
 Treatment plant flow control
 Pressure regulating
 Turbine by-pass

Product Attributes

High differential flow control
 Cavitation control
 Linear control characteristics
 DN 200 – 1400
 PN 10 - 40

Approvals/Standards

Flanges to EN 1092-2 as standard
 Other flange standards available

Quality

ISO 9001:2008 Quality Management Standard

We are the supply partner of choice for New Zealand's civil construction industry, specialising in water and infrastructure based solutions.

Needle valves are designed to manage flow control for continuous operation. Water flow is guided in a ring shaped cross section from inlet to discharge port. This allows the valve to control flow, pressure and high differential in various applications while preventing cavitation damage.

Design properties

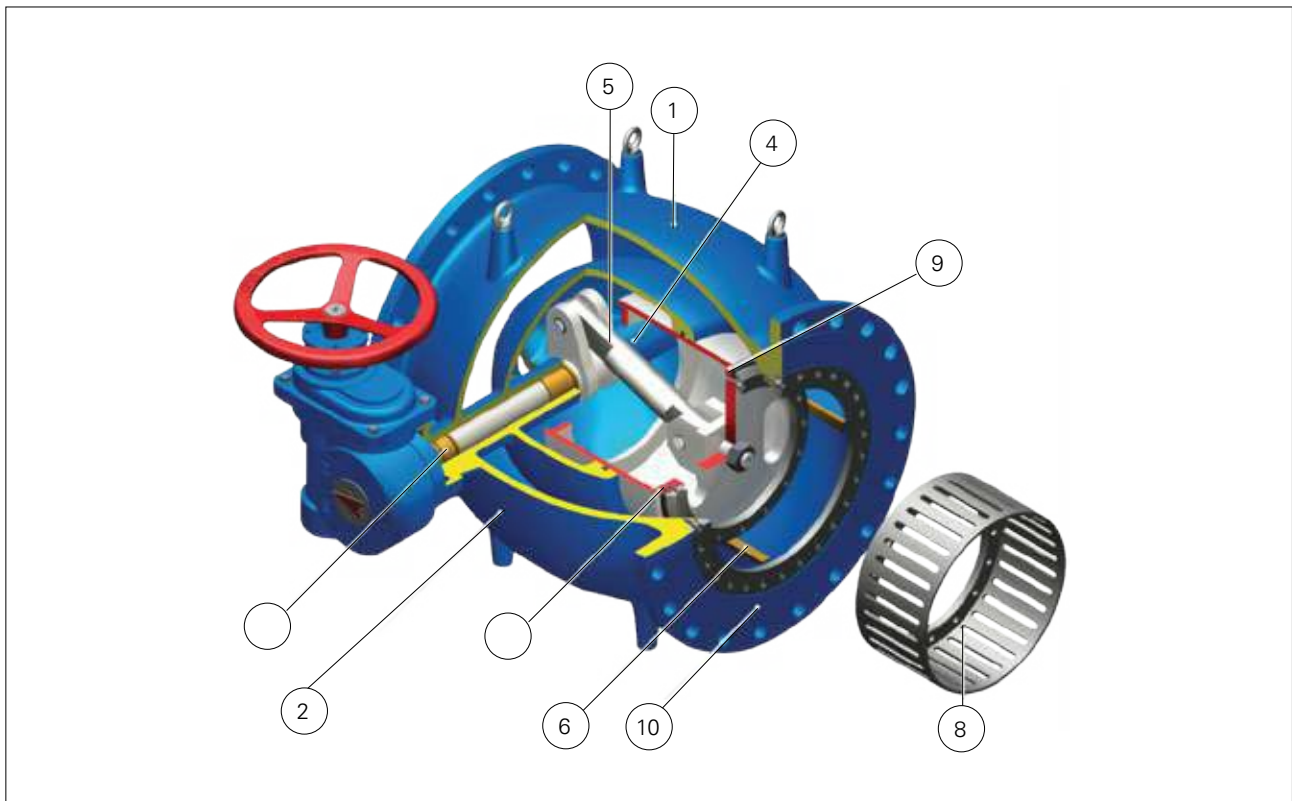

FIG. 1

1. Optimised body design for better flow guiding and minimum head loss in full open position
2. Single piece compact body
3. Maximum service life due to the cavitation-free location of seal ring
4. Drive shaft supported on both sides in lubricated maintenance free bushings
5. Stainless steel internal parts and fittings
6. Wear and corrosion resistant bronze weld overlay-finished piston guides
7. Double O-ring sealed shaft
8. Optional control devices for optimum cavitation-free control requirements
9. Field replaceable seat ring-requires no special tools
10. Fusion Bonded Epoxy coating

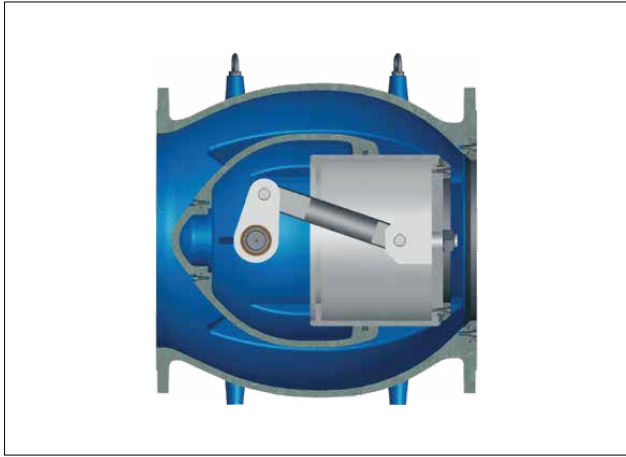

FIG. 2



FIG. 6

- The piston and crank mechanism are located in a teardrop shaped internal body.
- The piston is axially guided inside the internal body and linear movement of piston changes cross-section.
- The piston is driven by crank mechanism which transforms rotational movement of gearbox or other actuation devices to linear movement.

Options

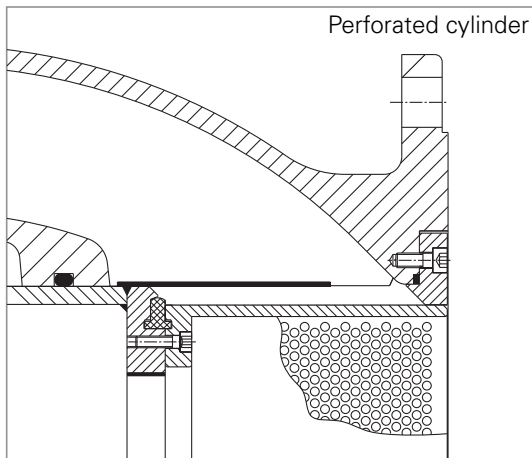

FIG. 3

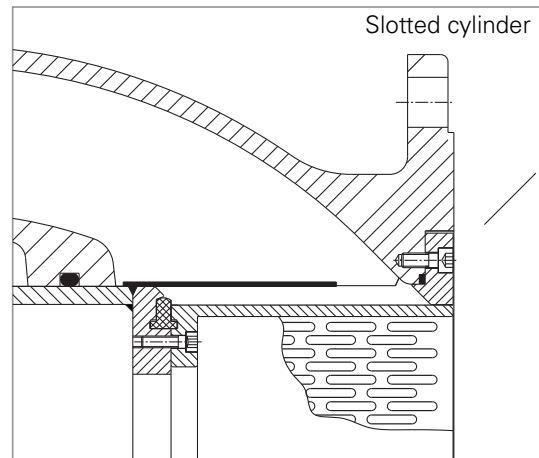

FIG. 4

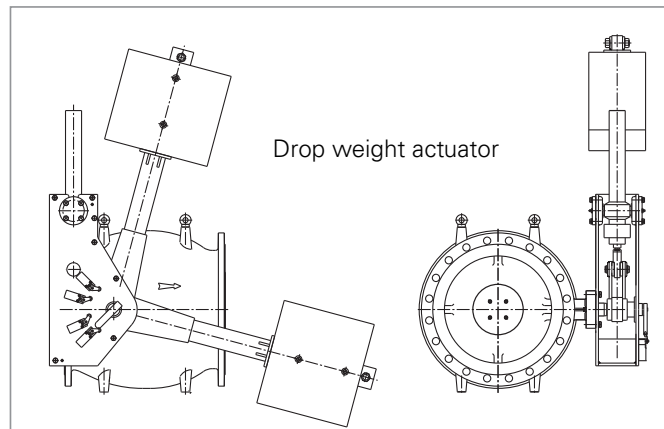

FIG. 5

Material properties

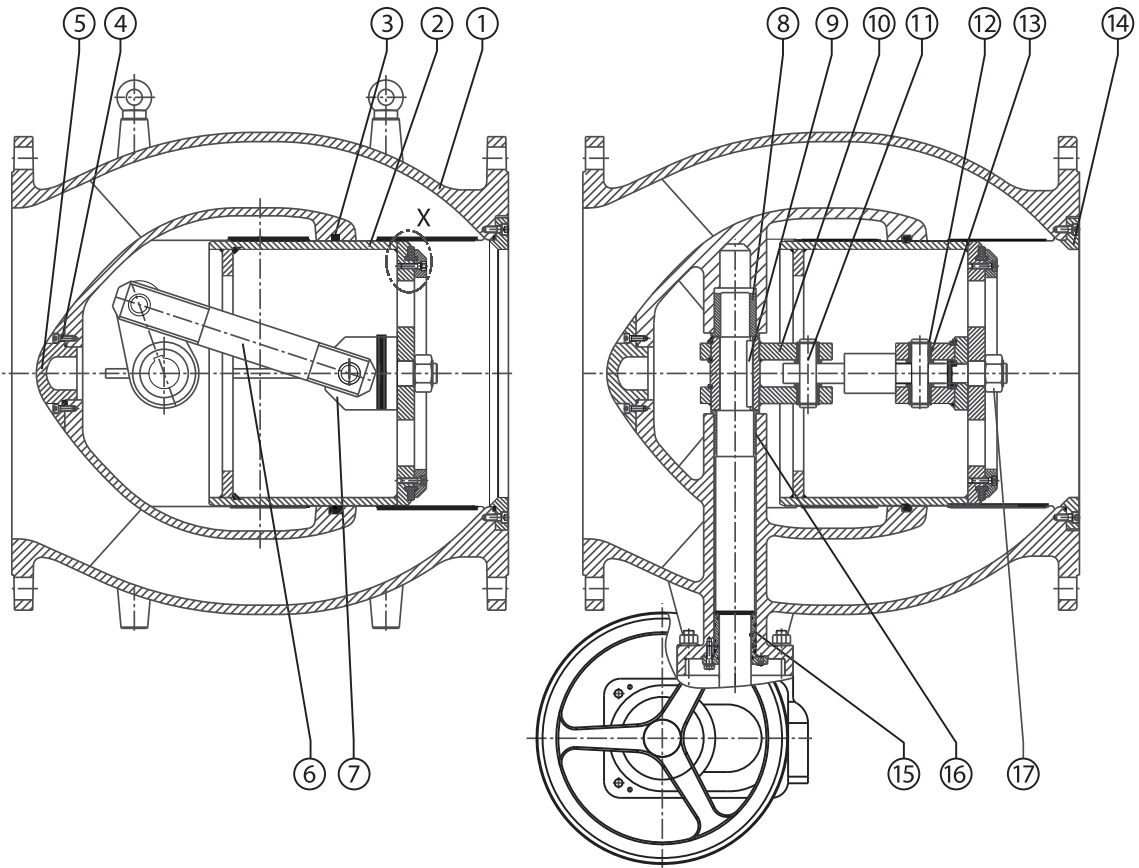

FIG. 7

TABLE 1

Part No.	Description	Material
1	Body	Ductile iron EN-GJS-400-15
2	Piston	Stainless steel 1.40301
3	Seal	Rubber NBR
4	Hex. Socket head cap screw	Stainless steel A2
5	Cap	Ductile iron EN-GJS-400-15
6	Connecting rod	Stainless steel 1.4021
7	Piston hub	Stainless steel 1.4301
8	Bearing bush	Bronze G-Cu Sn12
9	Key	Stainless steel 1.4021
10	Crank	Ductile iron EN-GJS-400-15
11	Crank pin	Stainless steel 1.14021
12	Circlip	Stainless steel 1.4301
13	Bearing bush	Bronze G-Cu Sn12
14	Seat ring	Stainless steel 1.4301
15	Shaft bearing bush	Bronze G-Cu Sn12
16	Bearing bush	Bronze G-Cu Sn12
17	Nut	Stainless steel 1.4301

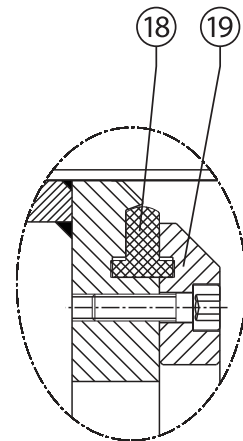

FIG. 8

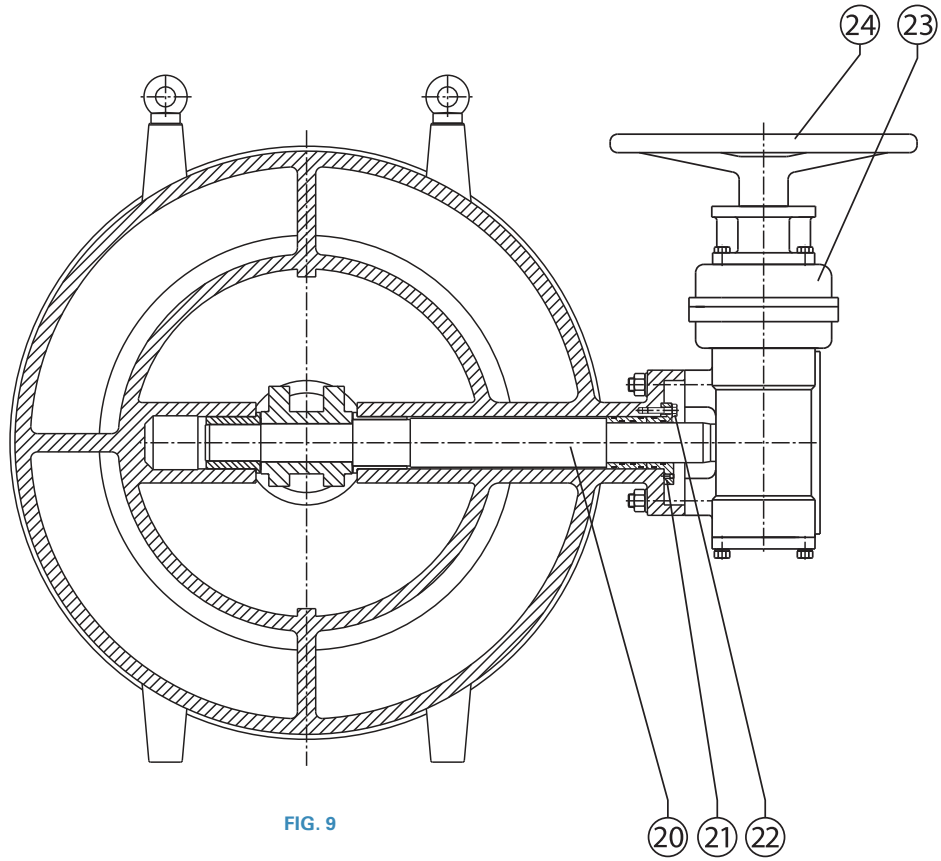

FIG. 9

TABLE 2

Part No.	Description	Material
18	Seal ring	Rubber EPDM
19	Retaining ring	Stainless steel 1.4301
20	Shaft	Stainless steel 1.4301
21	Cover	Ductile iron EN-GJS-400-15
22	Hex. bolt	Stainless steel A2
23	Worm gear box	-
24	Hand wheel	-

Technical Information

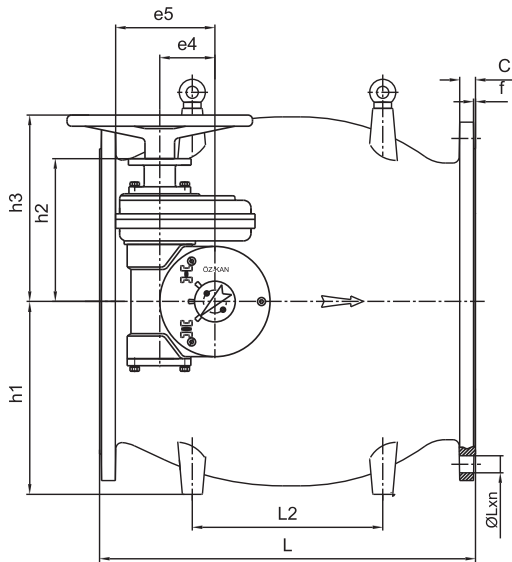

FIG. 10

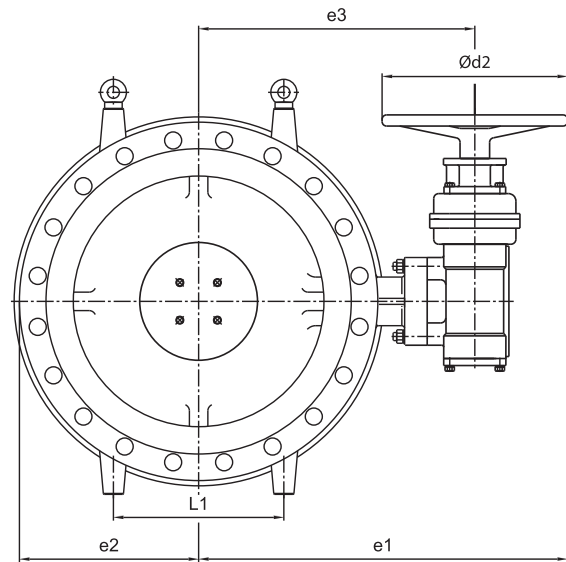
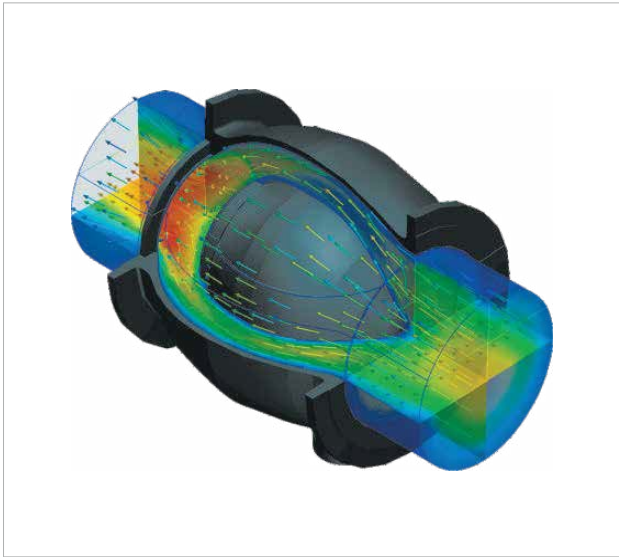

FIG. 11

TABLE 3

DN	L	L1	L2	e1	e2	e3	e4	e5	Ød2	h1	h2	h3	GEARBOX
200	400	140	200	445	188	312	95	158	245	198	163	239	TK2
250	450	170	230	480	200	357	95	158	245	235	163	239	TK2
300	500	200	250	518	230	395	95	158	245	268	163	239	TK2
350	550	240	280	558	260	435	95	158	245	300	163	239	TK2
400	600	270	300	656	296	471	110	175	370	340	184	271	TK3
450	650	300	330	695	330	510	110	175	370	353	184	271	TK3
500	750	340	380	736	370	551	110	198	370	388	285	372	TK4-RD4
600	900	400	450	821	440	636	156	245	370	455	334	420	TK4-RD4
700	1050	470	530	908	510	723	190	313	370	520	397	484	TK5-RD5
800	1200	540	600	978	580	793	190	313	370	590	397	484	TK5-RD5
900	1350	600	680	1048	655	863	190	313	370	670	397	484	TK5-RD5
1000	1500	670	750	1131	730	946	242	365	370	750	432	519	TK6-RD6
1200	1800	800	900	1277	865	1092	242	365	370	880	432	519	TK6-RD6
1400	2100	940	1050	1442	1015	1257	242	365	370	1030	432	519	TK6-RD6
1600	2400	1070	1200	1680	1153	1437	290	515	485	1180	538	625	TK7-RD7

Inquiry / Order Data



What we need to know about your application

- Medium
- Application, intended use
- Operation mode (continuous, short term)
- Flow rates Q_{max} Q_{min}
- Upstream pressure at Q_{max} and Q_{min} flow rates
- Downstream pressure at Q_{max} and Q_{min} flow rates
- Actuator requirement
- Special material requirements

FIG. 12



FIG. 13 Converging water streams concentrate vapour bubbles in the centre of the flow to limit cavitation damage and dissipate energy

W4104_02102014NE11EEDV1E1V1E1|P1E1E1S1U1P1E1L1K1S1E1E1N1E1G1B1G18

Branches Nationwide *Support Office & Technical Services 0800 93 7473*

Disclaimer: While every effort has been made to ensure that the information in this document is correct and accurate, users of Hynds product or information within this document must make their own assessment of suitability for their particular application. Product dimensions are nominal only, and should be verified if critical to a particular installation. No warranty is either expressed, implied, or statutory made by Hynds unless expressly stated in any sale and purchase agreement entered into between Hynds and the user.

hyndswater.co.nz
0800 93 7473

HYNDSwater