

# HDPE Grease Trap System

(Oil & Water Management)

Technical Guide SW 4



Heavy duty polyethylene grease trap units offer a simple and effective solution that intercepts and helps to retain the flow of greasy fluids and solids, before reaching downstream pipe networks.



08.17 | STORMWATER | SW4 HDPE GREASE TRAP SYSTEM

## Applications

Cafes  
Restaurants  
Commercial kitchens and galleys

## Product Attributes

Easy installation and maintenance  
Lightweight and easy to relocate  
Manufactured using heavy duty polyethylene for durability  
Designed to encourage congealing of grease and fats

## Quality

ISO 9001:2008 Quality Management Standard

*The go to organisation for stormwater, industrial waste, and wastewater engineered systems*

**HYNDS**  
PIPE SYSTEMS

A polyethylene grease trap designed for separating organic fats and oils (animal and plant based) from water using gravity.

### Features

- Grease that is hot or contained in hot water maintains a liquid state. However, when allowed to cool, grease sticks to the sides of the pipes and cause blockages.
- HDPE grease trap units intercept and retain greasy fluid within multiple chambers prior to discharge. The HDPE grease trap unit features outlets near the bottom of each chamber that forces liquid to follow the longest route towards the outlet, trapping grease as it rises to the top of the unit in a semi-solidified state.
- Settleable solids are retained in the base of the unit.

### Installation

- HDPE grease trap systems are best suited for sites with difficult access.
- The system is made from lightweight polyethylene material, therefore only two people are required to lift the unit into place.
- A grease trap should be sited before the onsite wastewater treatment system.

### Operation

- Effective grease and oil separation is provided with calm and cooling conditions.
- The less agitation or turbulence of contaminated liquid will encourage de-emulsified globules to rise to the surface.

**TABLE 1** HDPE Grease Trap product information

Product Code	Capacity (litres)
GTPOLY100LTR	100
GTPOLY150LTR	150
GTPOLY250LTR	250
GTPOLY500LTR	500

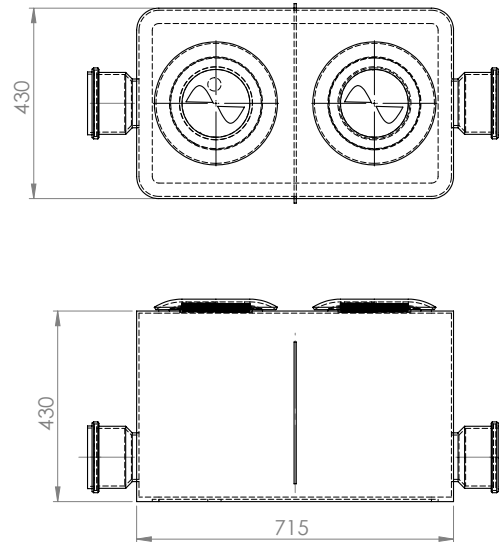

**FIG. 1** 100L Grease Trap



**FIG. 2** Various size options available

Branches Nationwide Support Office & Technical Services 09 274 0316

**Disclaimer:** While every effort has been made to ensure that the information in this document is correct and accurate, users of Hynds product or information within this document must make their own assessment of suitability for their particular application. Product dimensions are nominal only, and should be verified if critical to a particular installation. No warranty is either expressed, implied, or statutory made by Hynds unless expressly stated in any sale and purchase agreement entered into between Hynds and the user.