

Hynds U-Culvert & Base System South Island



Technical Guide D8.2

Hynds precast concrete U-Culvert & Base units provide customisable underpass solutions with a smoother surface and longer lifespan (50-100 yrs) than steel alternatives.



D8.2 HYNDS U-CULVERT BASE UNDERPASS SYSTEM | DRAINAGE | 03.15

Applications

Stock Underpasses

Pedestrian tunnels

Roading culverts

Product Attributes

Large range of strengths and opening sizes

Customisable for special conditions or shapes

Simplifies preparation of site plans for council approval

Suitable for high-water table installation issues

Fast and cost effective installation method

Approvals/Standards

Custom-built for load configurations up to HN:HO:72

Quality

ISO 9001:2008 Quality Management Standard

The go to organisation for civil and rural product solutions

HYNDS

Hynds precast concrete U-Culvert and Base units provide customisable underpass solutions with a smoother surface and longer lifespan (50-100 yrs) than steel alternatives.

Design Specifications

- Hynds precast reinforced U-Culvert and base units are made to order. (Please ensure an approximate lead time is stated at time of the order enquiry.)
- A variety of opening sizes are available to suit most farm types and stock quantities.
- Standard sizes are detailed in Table 1.
- Stock Underpasses for Rural Crossings: The size of stock underpasses are normally determined by the size of the herd or machinery that will use the underpass.
- Pedestrian Tunnels: Opening size is to be determined by the tunnel space desired. For Pedestrian Tunnels, this is usually dependant on the NZ Building Code.

TABLE 1 Standard U sizes

Width	Height	
	2000	2500
3000	✓	✓
3500	✓	✓
4000	✓	✓
4500	✓	✓
5000	✓	✓
5500	✓	✓
6000	✓	✓

Standard unit length is 2250 mm (other sizes made to order)

Product Code	Description	Size
BXU 3000 2000	Lid	3 x 2
BXB 3000 2000	Base	
BXU 3500 2000	Lid	3.5 x 2
BXB 3500 2000	Base	
BXU 4000 2000	Lid	4 x 2
BXB 4000 2000	Base	
BXU 4500 2000	Lid	4.5 x 2
BXB 4500 2000	Base	
BXU 5000 2000	Lid	5 x 2
BXB 5000 2000	Base	
BXU 5500 2000	Lid	5.5 x 2
BXB 5500 2000	Base	
BXU 6000 2000	Lid	6 x 2
BXB 6000 2000	Base	

Wingwall Options

- Hynds supply wingwall panels with fixing holes and fixing sets so that the panels can be fixed to the U-Culvert.
- These panels have reinforcing starter bars protruding at the bottom of the panel that are fixed to the base reinforcing mat.
- The base is then poured in-situ on site by the contractor.

Headwall Options

- Hynds will supply the end units of the conduit structure with suitable headwalls as part of the U Culvert unit if requested.

Unit Strength

- Unit strength is dependent on earth loads, highway loads and cover to the finished culvert.

Concrete Surface Finishes

- Hynds U-Culverts are generally manufactured to F3/ F4 finish as detailed in NZS 3114:1987 – Specification for concrete surface finishes. This finish is typical of structures which will not be seen or are only going to be observed from a distance.
- Higher classes of finish may be required in elements subject to frequent observation (F4), subject to frequent close scrutiny (F5) or elements with painted surfaces. In these instances the finish required must be advised at time of quotation.
- Units are designed to corrosion protection exposure classification B2 (refer to NZS 3101). Consult an engineer where exposure classification C or U is required (seawater tidal/splash zone or similar aggressive environment).

Installation

- As per NZ Building Code, please check with local council for present building requirements.
- Culvert and wingwall units are delivered to site by our trucks. Off-loading can be arranged if required.

- Culvert installation should be done by an experienced contractor who understands the necessity of jointing, bedding and backfilling the structure properly as well as the highway safety requirements applicable to such an installation.
- An installation guide will be supplied on confirmation of orders.

Handling

- U-Culvert and Base units are normally supplied with swift-lift anchors cast into the top of each unit.
- Appropriately rated chains and lifting beam must be used when handling the units.
- Lifting anchor positioning and lifting equipment specifications can be supplied upon request.

Basic Bedding Preparation

- Sufficient foundation support and backfill compaction is required to prevent settlement of the imported layers conduit after installation.
- The bedding must be able to support the full load of the installed culvert, its contents, and the loads above the culvert. For this reason the U-Culvert should be laid on compacted granular hard fill to the specified line and gradient.
- Bedding design for a U-Culvert conduit should be undertaken by a local consulting engineer as local knowledge of ground conditions is important to ensure a successful installation.
- As a general guide, the compacted thickness of a basic bedding over the full width of the trench can vary between 150 to 250 mm (depending on culvert bearing loads) with compacted layers not exceeding 150 mm thick.
- Trench width for most installations should be equal to the external width of the culvert plus 600mm.
- Local soft spots in the trench must be excavated and the voids filled with well compacted hardfill to provide uniform support under the entire structure. Failure to do so could result in settlement of the units at a later stage.
- Additional information is available in AS/NZS 3725.



FIG. 1 Width and height diagram for Table 1

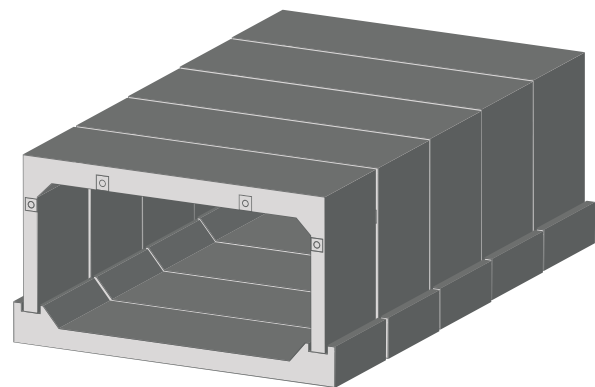

FIG. 2 Typical layouts and applications



Jointing

- Hynds U-Culverts are manufactured with a shear key detail which locates and locks adjacent units together.
- Joint gaps will vary from 5 to 20 mm and in most cases can be left open.
- Joint sealing can be formed with the use of butyl mastic sealing strips, epoxy, sand-mortar mix, or silicone sealant. Contact your local Hynds Sales Branch for these products.
- Drossbach ducts are to be filled with a non-shrink cementitious grout.

Laying

- The U-Culvert units should be inspected before laying to ensure that the jointing surfaces are clean.
- The unit is then lowered carefully on to the prepared base aligning the spigot with the socket of the unit already laid.
- Loose surface bedding material must not enter the joint space between the units, particularly along the bottom, during positioning of the unit.
- If any adjustment of level is necessary, remove the U-Culvert, adjust the surface layer of the bedding and place again. Do not use local packers to adjust the level.
- Hynds U-Culvert and base units are manufactured with a duct in each corner. The units can then be bolted together or post tensioned on site once the units have been installed.
- Recommended practice is to insert the tie rods as the first unit is placed and push through subsequent units as they are installed.

Backfilling

- Backfilling should commence as soon as possible after the U-Culvert and base units have been laid.
- Fill the trench to the level of the top of the culvert working evenly on each side.
- Use selected backfill material well compacted in layers not exceeding 200 mm thickness.
- Do not use heavy vibratory equipment.
- Continue to fill the culvert conduit in well compacted layers.
- Do not run heavy rollers or construction equipment over the culvert conduit without checking beforehand that the units are designed to withstand these loads.

Branches Nationwide Support Office & Technical Services 09 274 0316

Disclaimer: While every effort has been made to ensure that the information in this document is correct and accurate, users of Hynds product or information within this document must make their own assessment of suitability for their particular application. Product dimensions are nominal only, and should be verified if critical to a particular installation. No warranty is either expressed, implied, or statutory made by Hynds unless expressly stated in any sale and purchase agreement entered into between Hynds and the user.