

# RECYFIX® NC

Technical Guide D17.7

An industrial grade channel system for those demanding heavy duty applications.



08.23 | DRAINAGE | D17.7 HAURATON RECYFIX NC

## Applications

High intensity forklift areas  
 Container handling facilities  
 Ports and inland ports  
 Fuel installations

## Product Attributes

Stable and lightweight linear drainage made of PP  
 Load capacity up to E 600kN  
 Maximum security with 8 bolt fixing  
 Very lightweight, quick and cost effective installation

## Approval/ Standards

Load rating as per EN 1433

## Quality

ISO 9001:2008 Quality Management System

*We are the supply partner of choice for New Zealand's civil construction industry, specialising in water and infrastructure based solutions.*

# RECYFIX® NC

Engineered to be lightweight yet extremely stable.

## Requirement

- Modern drainage systems must permanently withstand high loads and large forces
- Be easy to install
- Be resistant to environmental influences (frost, heat, humidity)
- Comply with EN 1433

## Solutions

- Channels made of recycled Polypropylene
- Load capacity up to E 600kN according to EN 1433
- Maximum security through 8-fold bolt fixing
- Very lightweight, quick and cost saving installation
- High capacity slot for improved hydraulic performance

## Applications

- High intensity forklift areas
- Container handling facilities
- Ports and inland ports
- Fuel installations



FIG. 1 Service Station, Sanson

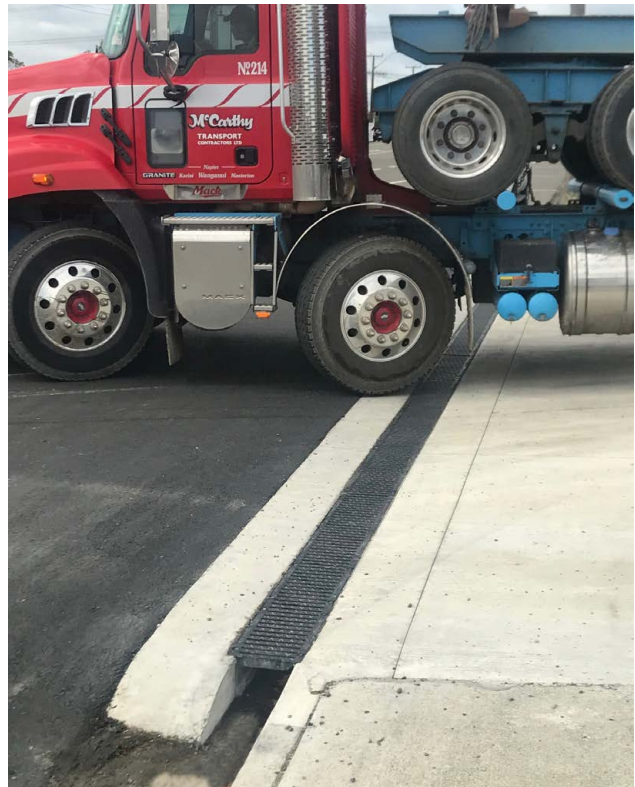

FIG. 2 Service Station, Sanson

## The benefits of RECYFIX® NC Channels

**High stability**

- Stable, durable ductile iron grating
- High quality ductile iron
- 8-fold bolted

**= Security**

**Prefabricated ready to install**

- Channel and grating = one part
- Easy handling in stock and on site
- Cost-effective transportation

**= Lower costs**

**Standards and approvals**

- Certified to EN 1433
- CE-marking

**= Security**

**Low weight ensures easy handling on site**

- Very easy handling and installation
- Maximum stability with minimum weight

**= Cost savings**

**High-grade material**

- RECYFIX® – stable and almost unbreakable
- Flexible and particularly resistant material
- Withstands high traffic loads and temperature differences in daily use

**= Security**

# Components

## Load Classes

European Standard EN 1433



Load Class E 600kN  
Approximate Wheel Load 20,000kg

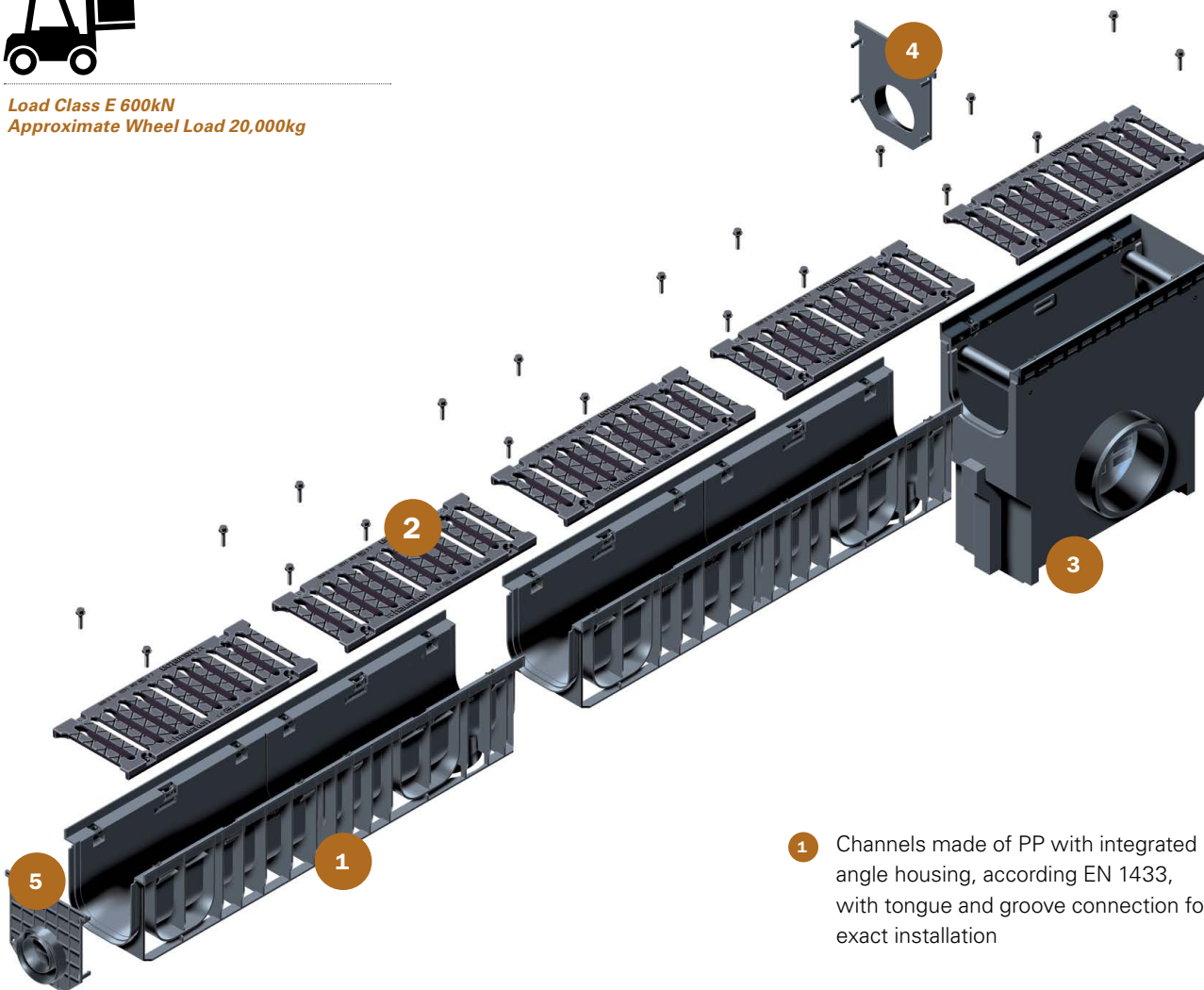

- 1 Channels made of PP with integrated angle housing, according to EN 1433, with tongue and groove connection for exact installation
- 2 Stable ductile iron grating made of durable spheroidal ductile iron
- 3 Trash box with 2-sided pipe connection possibilities
- 4 End caps without outlet
- 5 End cap with outlet

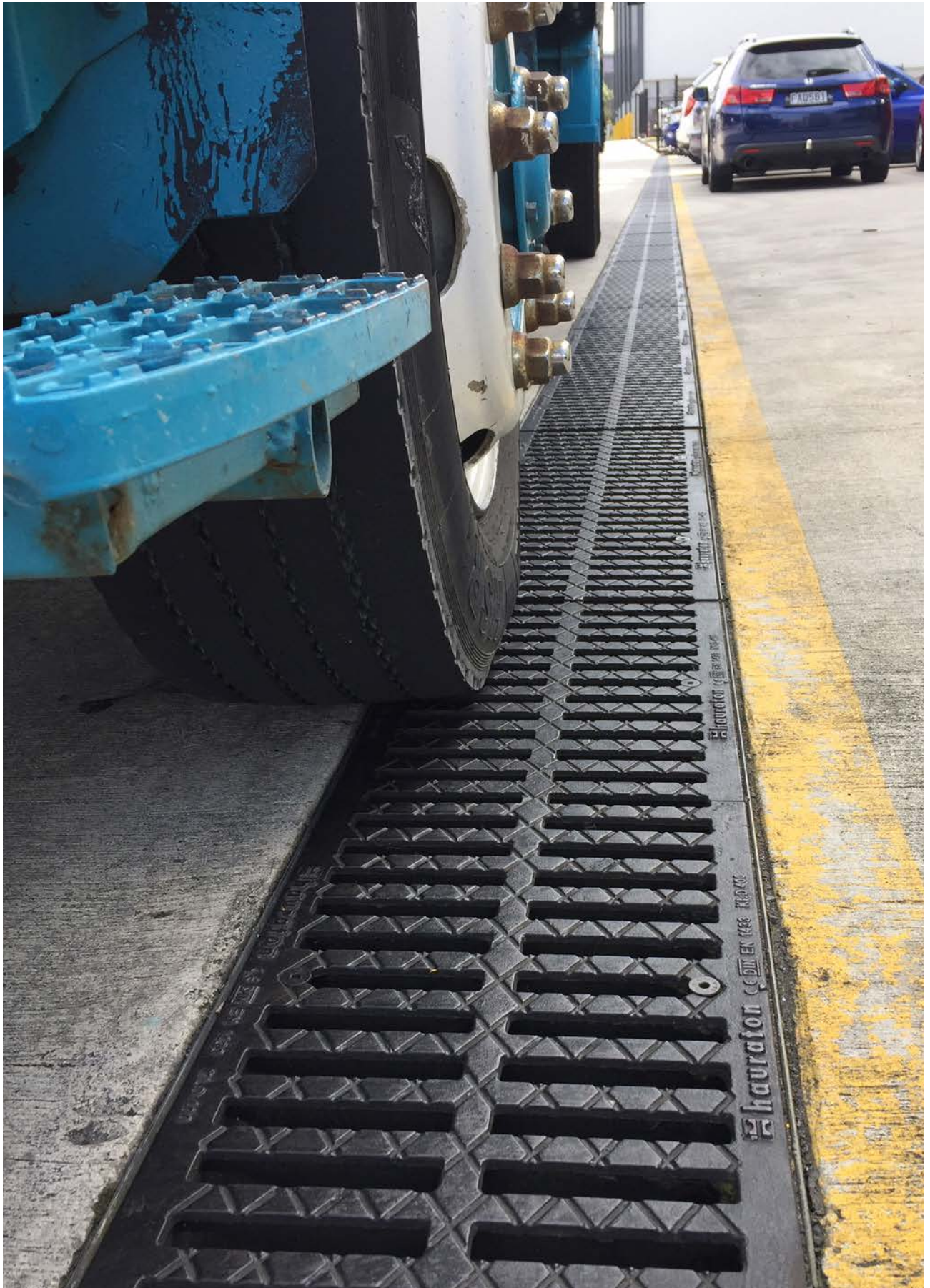

FIG. 3 RECYFIX® NC 300 D 400kN

# RECYFIX® NC 100

Class E 600kN

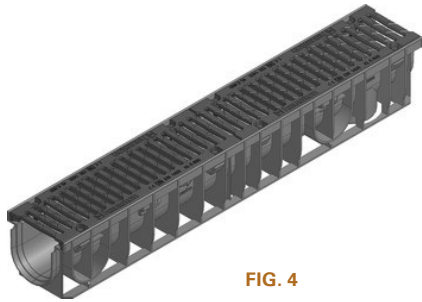

FIG. 4

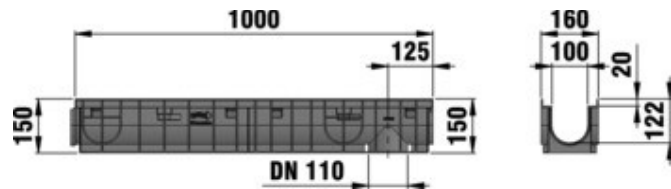

FIG. 5

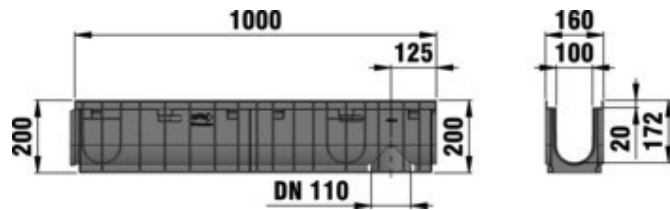

TABLE 1 RECYFIX® NC 100 E 600kN

Code	Description	Length mm	Width mm	Height mm	Drainage cross-sect cm <sup>2</sup>	Intake cross-sect cm <sup>2</sup> /m	Weight kg	Figure #
CHH01401904	Channel NC 100 DI Slotted 10mm Type 01	1000	160	150	92	427	10.7	4
CHH01401905	Channel NC 100 DI Slotted 10mm Type 010	1000	160	200	142	427	11.9	5

## Accessories

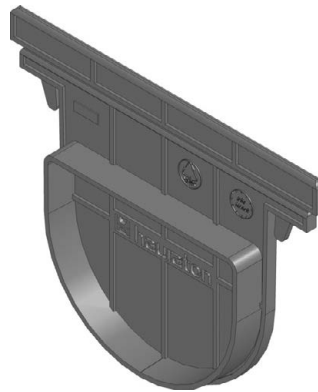
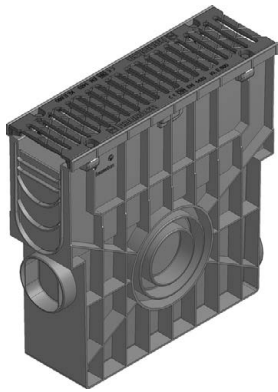

FIG. 6

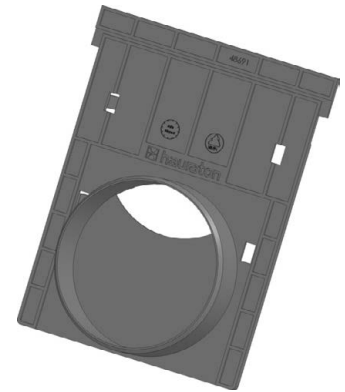

FIG. 7

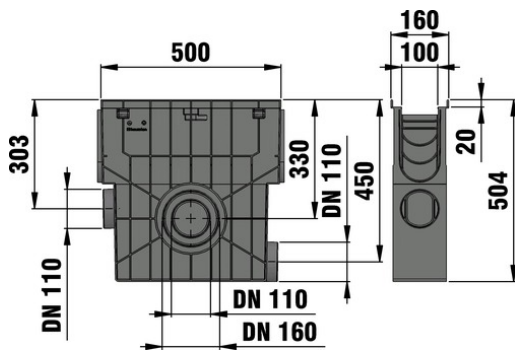

FIG. 8



FIG. 9

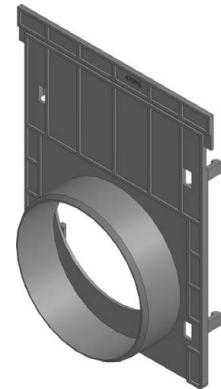

FIG. 10

TABLE 2 RECYFIX® NC 100 E 600kN Accessories

Code	Description	Length mm	Width mm	Height mm	Figure #
CHH01401300.1	Trash Box NC 100 DI Slotted 10mm	1000	160	150	6
CHH01401300.2	End Cap PRO NC 100 Blank Type 01	17	160	124	7
CHH01401300.3	End Cap PRO NC 100 Type 01 with 100mm PVC Outlet	34	160	200	8
CHH01401300.4	End Cap PRO NC 100 Blank Type 010	5	160	176	9
CHH01401300.5	End Cap PRO NC 100 Type 010 with 100mm Outlet	34	160	200	10

# RECYFIX® NC 150

Class E 600kN

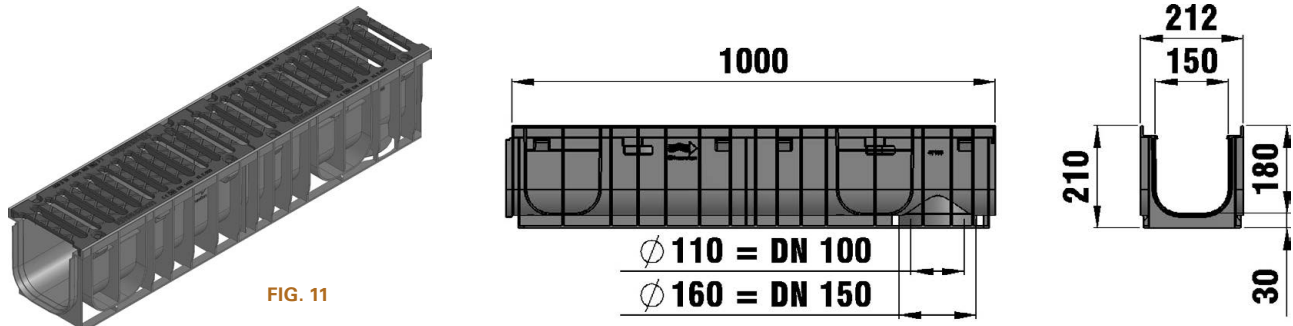

FIG. 11

TABLE 3 RECYFIX® NC 150 E 600kN

Code	Description	Length mm	Width mm	Height mm	Drainage cross-sect cm <sup>2</sup>	Intake cross-sect cm <sup>2</sup> /m	Weight kg	Figure #
CHH01401910	Channel NC 150 DI Slotted 18mm Type 01	1000	212	210	230	702	15.7	11

## Accessories

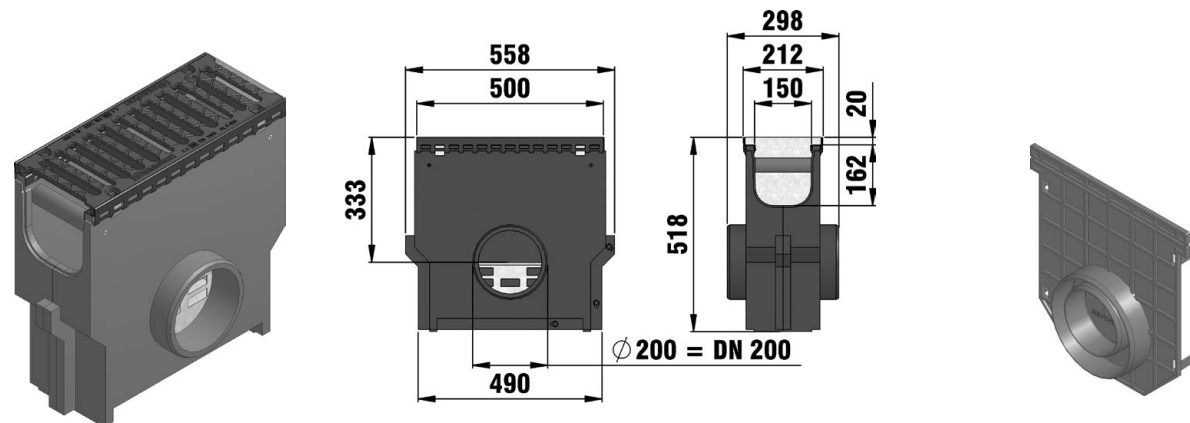

FIG. 12

FIG. 13

TABLE 4 RECYFIX® NC 150 E 600kN Accessories

Code	Description	Length mm	Width mm	Height mm	Figure #
CHH01401364.1	Trash Box NC 150 DI Slotted 10mm	500	212	518	12
CHH01401364.2	End Cap PRO NC 150 Type 01 with 75-110 PVC Outlet	24	210	218	13



# RECYFIX® NC 200

Class E 600kN

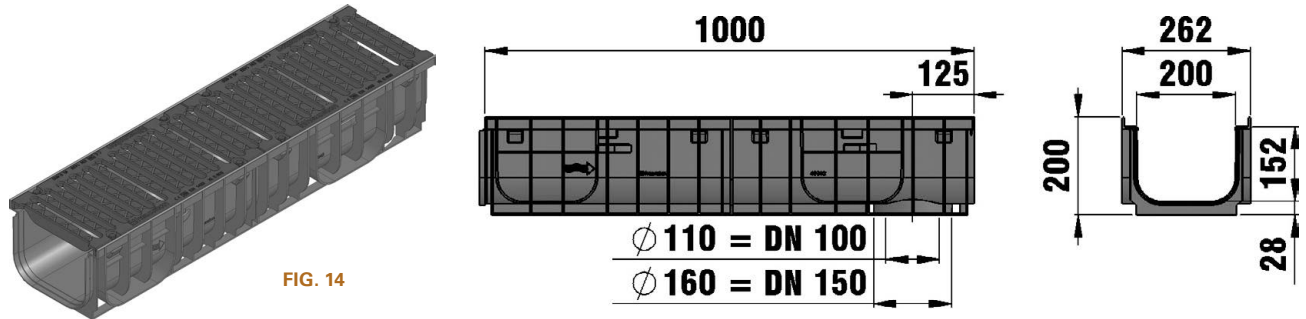

FIG. 14

TABLE 5 RECYFIX® NC 200 E 600kN

Code	Description	Length mm	Width mm	Height mm	Drainage cross-sect cm <sup>2</sup>	Intake cross-sect cm <sup>2</sup> /m	Weight kg	Figure #
CHH01401912	Channel NC 200 DI Slotted 18mm Type 010	1000	262	200	294	936	20.8	14

## Accessories

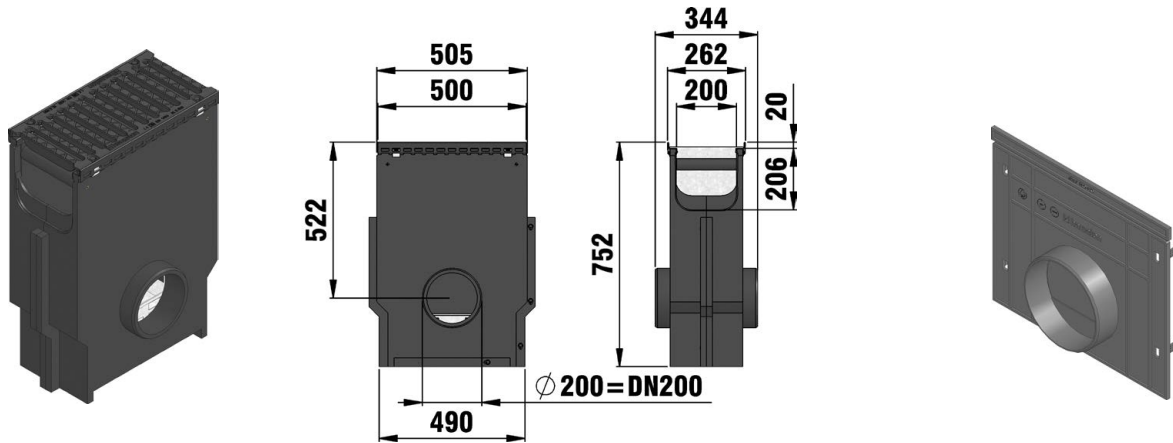

FIG. 15

FIG. 16

TABLE 6 RECYFIX® NC 200 E 600kN Accessories

Code	Description	Length mm	Width mm	Height mm	Figure #
CHH01401375.1	Trash Box NC 200 DI Slotted 18mm with Mud Bucket	500	262	752	15
CHH01401375.2	End Cap PRO NC 200 Type 010 with 100mm PVC Outlet	28	258	217	16

# RECYFIX® NC 300

Class E 600kN

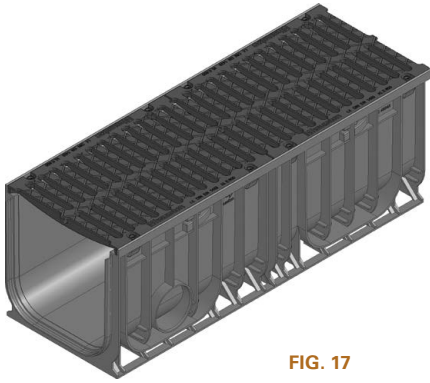

FIG. 17

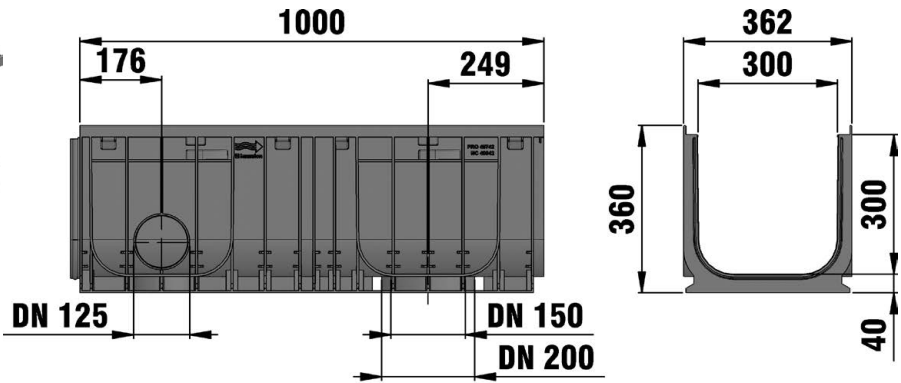

TABLE 7 RECYFIX® NC 300 E 600kN

Code	Description	Length mm	Width mm	Height mm	Drainage cross-sect cm <sup>2</sup>	Intake cross-sect cm <sup>2</sup> /m	Weight kg	Figure #
CHH01401914	Channel NC 300 DI Slotted 18mm Type 010	1000	362	360	873	1293	35	17

## Accessories



FIG. 18

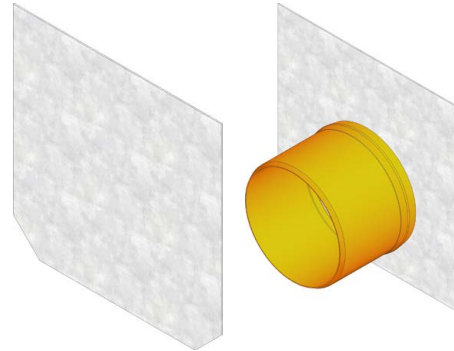
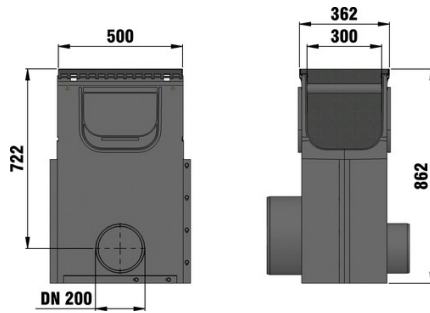

FIG. 19

FIG. 20

TABLE 8 RECYFIX® NC 300 E 600kN Accessories

Code	Description	Length mm	Width mm	Height mm	Figure #
CHH01401385	Trash Box NC 300 DI Slotted 18mm with Mud Bucket	500	362	862	18
CHH01401390	End Cap PRO NC 300 Galv Blank Type 010	2	360	360	19
CHH01401395	End Cap PRO NC 300 Type 010 175mm PVC Outlet	154	360	360	20

# Installation Guidelines

**Installation example  
concrete class D 400 - E 600**

3-5 mm durable overhang

Expansion joint

Concrete wearing layer

Base course

Frost resistant sub-base

reinforcing steel bar  $\varnothing$  10 mm every 40 cm

\* y = Channel height plus camber

Category according to EN 1433 / DIN 19580	<b>A 15</b>	<b>B 125</b>	<b>C 250</b>	<b>D 400**</b>	<b>E 600</b>	<b>F 900</b>	Applying to following systems:
Foundation: width x / thickness z / height y (in cm)				15 / 15 / *	15 / 20 / *		<b>RECYFIX NC 100, 150, 200, 300</b>
The named concrete quality is a minimum quality***							
EN 206-1 / DIN 1045-2	quality of concrete stretcher			C 30/37 XF 4	C 30/37 XF 4		
	with danger of frost on the lateral support			C 30/37 XD 1	C 30/37 XD 1		
The installation examples / advise constantly are adapted to the technical conditions. With new editions older expenditures lose their validity. Before planning or installation please verify the current version at <a href="http://www.hauraton.com">www.hauraton.com</a> in building construction is a sealing layer below the channels necessary.				Date: 24.10.2018	Our general installation instructions apply.		Format DIN A4
** Not for use in continuously frequented areas of carriageways or motorways *** European Standard. C 20/25 = minimum 25mPa, C 30/37 = minimum 37mPa				0000049541.DWG EBBw			scale 1:5
				RF-NC-100 Typ 010 Rinnenunterteil Einbaubeispiel Klasse D 400 in Beton		 Unit 4, Frenchs Avenue LU6 1BH Dunstable / Bedfordshire Tel. +44 1582 50 1380 technical@hauraton.co.uk	

**Installation example  
in asphalted areas class D 400 - E 600**

3-5 mm durable overhang

Bituminous joint strip

Wearing course

Binder course

Base course

Frost resistant sub-base

reinforcing steel bar  $\varnothing$  10 mm every 40 cm

\* y = Channel height plus camber

Category according to EN 1433 / DIN 19580	<b>A 15</b>	<b>B 125</b>	<b>C 250</b>	<b>D 400**</b>	<b>E 600</b>	<b>F 900</b>	Applying to following systems:
Foundation: width x / thickness z / height y (in cm)				15 / 15 / *	15 / 20 / *		<b>RECYFIX NC 100, 150, 200, 300</b>
The named concrete quality is a minimum quality***							
EN 206-1 / DIN 1045-2	quality of concrete stretcher			C 30/37 XF 4	C 30/37 XF 4		
	with danger of frost on the lateral support			C 30/37 XD 1	C 30/37 XD 1		
The installation examples / advise constantly are adapted to the technical conditions. With new editions older expenditures lose their validity. Before planning or installation please verify the current version at <a href="http://www.hauraton.com">www.hauraton.com</a> in building construction is a sealing layer below the channels necessary.				Date: 24.10.2018	Our general installation instructions apply.		Format DIN A4
** Not for use in continuously frequented areas of carriageways or motorways *** European Standard. C 20/25 = minimum 25mPa, C 30/37 = minimum 37mPa				0000049864.DWG EBBw			scale 1:5
				RF-NC-100 Typ 010 Rinnenunterteil Einbaubeispiel Klasse D 400 in Asphalt		 Unit 4, Frenchs Avenue LU6 1BH Dunstable / Bedfordshire Tel. +44 1582 50 1380 technical@hauraton.co.uk	

**Branches Nationwide** *Support Office & Technical Services 0800 93 7473*

**Disclaimer:** While every effort has been made to ensure that the information in this document is correct and accurate, users of Hynds product or information within this document must make their own assessment of suitability for their particular application. Product dimensions are nominal only, and should be verified if critical to a particular installation. No warranty is either expressed, implied, or statutory made by Hynds unless expressly stated in any sale and purchase agreement entered into between Hynds and the user.

**hynds.co.nz**  
**0800 93 7473**

**HYNDS**  
PIPE SYSTEMS

The logo for Hynds Pipe Systems features the word "HYNDS" in a large, bold, white sans-serif font. Below it, the words "PIPE SYSTEMS" are written in a smaller, white sans-serif font. A yellow curved line, resembling a stylized pipe or a smile, is positioned at the bottom of the logo.