

Dismantling Joints Flanged to AS 4087

Technical Guide W5.10

Viking Johnson versatile Dismantling Joints flanged to AS 4087 create easily serviceable connections for valves, flow meters and critical junctions.



Applications

Allows adjustment in pipelines when connecting to: pumps, valves, flow meters and critical junctions

Allows pipeline adjustment during assembly

Product Attributes

Pre-assembled for ease of installation

Rilsan Nylon 11 coating for corrosion resistance

Stainless Steel Tie Bolts

Thrust rated when using the tie bolts

Approvals/Standards

AS/NZS 4020 & WRAS approval for use with potable water

Flange drilled to AS 4087 Fig. B5

Quality

ISO 9001:2000 Quality Management System

We are the supply partner of choice for New Zealand's civil construction industry, specialising in water and infrastructure based solutions.

A Dismantling Joint is a double flanged fitting that allows longitudinal adjustment in flanged pipe systems whilst offering longitudinal restraint.

It has been developed to provide greater flexibility in flanged pipe systems and allows for subsequent maintenance.

Applications

- Designed for flanged pipe systems requiring longitudinal restraint and the need to be disassembled.
- Pressure water systems requiring end restraint allowing approximately 50 mm flange to flange movement.

Product Attributes

- Pre-assembled for ease of installation
- Steel components coated with Rilsan Nylon 11
- Stainless Steel Tie Bolts
- Thrust rated when using the tie bolts

Features

- Body made from Steel
- Body Seal EPDM to BS EN681-1
- Full face flanges to AS4087 PN16 Fig.B5
- Designed to be locked in place with supplied tie rods
- Stainless steel tie rods are accommodated within the bolt circle eliminating complex anchoring systems

Accessories

- Custom made dismantling joints available upon request
- Higher pressure rated joints up to PN40 available upon request

Testing and Ratings

- Rated to PN16
- Pressure tested at 24bar

Materials and Relevant Standards

Flange Drilling

- AS.NZS 4087:2011 Fig.B5

Flange Adaptor

- Body - Rolled Steel to BS EN 10025-2: Grade S275
- End Rings* - Typically Rolled Steel to BS EN10025-2 Grade S275 or Ductile Iron to BS EN1563
- Typically Steel Tube to BS EN10255 or Steel to BS EN10025-2 Grade S275JR

Flanged Spigot

- Flange - Steel to BS EN 10025-2: Grade S275JR
- Spigot* - Typically Steel Tube to BS EN10255: or Steel Tube to BS EN10216-1: Grade P265TR1 or Rolled Steel to BS EN 10025-2: Grade S2753
- Body Seal EPDM to BS EN681-1: Type WA WRAS Listed

Tie Rods & Nuts

- Tie Rods - Stainless Steel to BS EN ISO3506-1 Grade A4/316
- Nuts (4 per Tie Rod) - Stainless Steel to BS EN ISO3506-2 Grade A4/316

Studs/Nuts/Washers

- Studs - Stainless Steel to BS EN ISO3506-1 Grade A4/316
- Nuts* - Steel to BS4190: Grade 4 or Stainless Steel to BS EN ISO3506-2: Grade A4/316
- Washers* - Stainless Steel to BS1449:Part 2: Grade 304S15 or Stainless Steel to BS EN ISO3506-1 Grade A4/316

Note: *Specific product materials for each size available upon request

Dismantling Joint Products

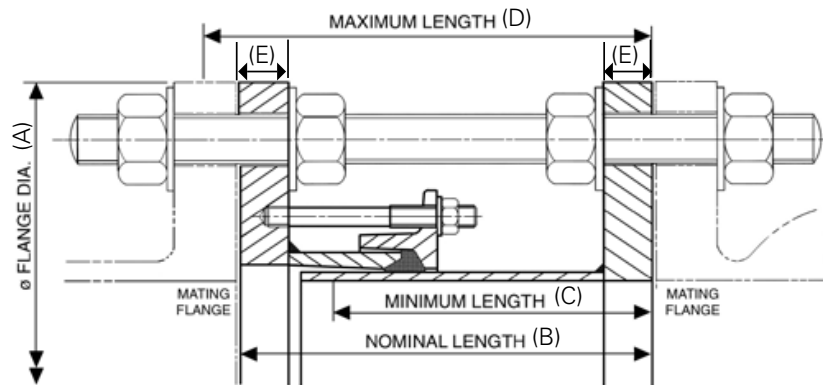

FIG. 1

Item Number	Nom	Flange details						Flange to Flange Details		Tie Rod (SS)		Total Weight (kg)
		Flange Thickness (E)	Flange OD (A)	PCD	# Holes	Diameter	Bolt size	Nom Length (B)	Max Adjust Length (C & D)	Dia x Length	No.	
GIBDJ100AS-SS	100	18	215	178	4	19	M16	187	+ - 20mm	M16 x 300	4	12.7
GIBDJ150AS-SS	150	18	280	235	8	19	M16	187	+ - 20mm	M16 x 300	4	18.3
GIBDJ200AS-SS	200	18	335	292	8	19	M16	187	+ - 20mm	M16 x 300	4	24.4
GIBDJ250AS-SS	250	18	405	356	8	23	M20	187	+ - 20mm	M20 x 300	4	34.3
GIBDJ300AS-SS	300	18	455	406	12	23	M20	187	+ - 20mm	M20 x 320	4	40.5
GIBDJ350AS-SS	350	18	525	470	12	28	M24	295	+ - 25mm	M24 x 440	4	62.6
GIBDJ375AS-SS	375	18	550	495	12	28	M24	295	+ - 25mm	M24 x 440	4	65.9
GIBDJ400AS-SS	400	18	580	521	12	28	M24	295	+ - 25mm	M24 x 440	4	70.6
GIBDJ450AS-SS	450	23	640	584	12	28	M24	300	+ - 25mm	M24 x 450	6	96.6
GIBDJ500AS-SS	500	23	705	641	16	28	M24	300	+ - 25mm	M24 x 460	8	114.6
GIBDJ600AS-SS	600	23	825	756	16	31	M27	300	+ - 25mm	M27 x 480	8	146.1
GIBDJ700AS-SS	700	23	910	845	20	31	M27	300	+ - 25mm	M27 x 500	10	162.4
GIBDJ750AS-SS	750	23	955	927	20	34	M30	300	+ - 25mm	M30 x 500	10	197.4
GIBDJ800AS-SS	800	23	1060	984	20	37	M33	300	+ - 25mm	M33 x 510	10	212.8
GIBDJ900AS-SS	900	25	1175	1092	24	37	M33	307	+ - 30mm	M33 x 540	12	286.6
GIBDJ1000AS-SS	1000	25	1255	1175	24	37	M33	307	+ - 30mm	M33 x 540	12	292.1

Notes: All Items PN16

Dismantling Joint Installation Instructions

Maximum Adjustment Lengths

Each Dismantling Joint has a specified flange to flange dimension, which positions the Dismantling Joint at its midpoint. The plus and minus dimension specified on the label are the maximum and minimum amounts of movement available to take up any site tolerances, i.e., they provide the maximum and minimum flange to flange dimensions respectively.

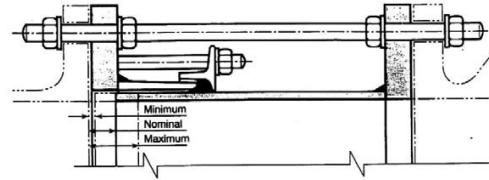

Installing Dismantling Joints

UP TO 300MM NOMINAL BORE

1. Position the spigot inside the flange adaptor until the front edge of the spigot is flush with the face of the flange adaptor (minimum flange to flange distance).
2. Position the Dismantling Joint between the two flanges to which it is to be connected. Withdraw the spigot until all the free play is taken up, ensuring the maximum flange to flange dimension is not exceeded.
3. Position flange connecting gaskets between both flange sets, and loosely assemble flange connecting bolts.
4. Remove all nuts and washers from the tie bars and insert them from one side in their appropriate positions. The nuts and washers have to be threaded back onto the tie bar in sequence as they are installed.
5. Tighten the flange connecting bolts and tie rods in accordance with standard procedures.
6. Tighten diametrically opposed flange adaptor studs giving the nuts one or two turns at a time to draw up the end ring evenly. The studs must be thoroughly tightened to the figures given in the 'Stud Torque Table', working around the flange adaptor as many times as necessary. Rubber may be seen to extrude into the gap between the end ring and spigot pipe.

OVER 300MM NOMINAL BORE

1. Place the end ring over the spigot pipe end, ensuring that the gasket chamber faces the plain end and the vertical end faces the flange.
2. Lubricate the gasket thoroughly with a thin film of Lubricant and stretch it onto the spigot pipe end, ensuring that the thicker or vertical end is towards the end ring.
3. Follow instructions 1, 2, 3, 4 and 5 on the left.
4. Slide the gasket forward into the gasket chamber of the flange adaptor (the end ring may assist in this operation).
5. Bring the end ring into position, locate the studs and fit the washers and nuts finger tight.
6. Tighten diametrically opposed flange adaptor studs giving the nuts one or two turns at a time to draw up the end ring evenly. The studs must be thoroughly tightened to the figures given in the 'Stud Torque Table', working around the flange adaptor as many times as necessary. Rubber may be seen to extrude into the gap between the end ring and spigot pipe.

Stud Torque Table

Bolt Size	Torque	
	lbf.ft	Nm
M12	40 - 50	55 - 65
M16	70 - 90	95 - 120

Branches Nationwide Support Office & Technical Services 0800 93 7473

Disclaimer: While every effort has been made to ensure that the information in this document is correct and accurate, users of Hynds product or information within this document must make their own assessment of suitability for their particular application. Product dimensions are nominal only, and should be verified if critical to a particular installation. No warranty is either expressed, implied, or statutory made by Hynds unless expressly stated in any sale and purchase agreement entered into between Hynds and the user.